

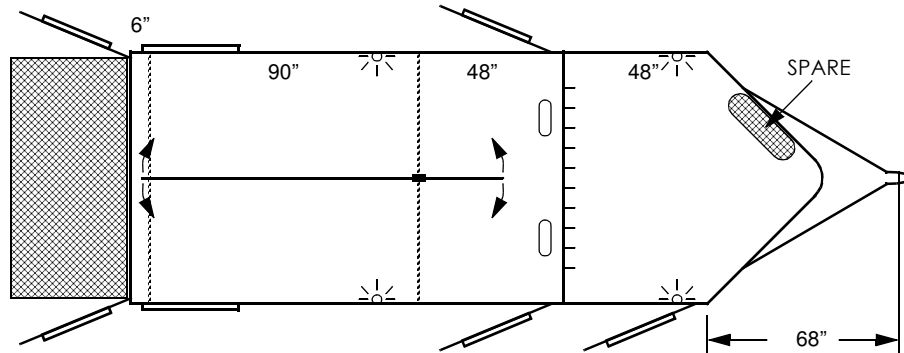

PLATINUM 2-H THOROUGHbred BUMPER PULL MANUFACTURING WARBLOOD 7' X 16' X 7'-6" TALL XB7162S



TOWING

2 5/16" BULLDOG COUPLER (12,500# RATING)
SAFETY CHAINS WITH SAFETY HOOK LATCHES
7-WAY FLAT PRONG PLUG & CABLE
A-FRAME JACK WITH REMOVABLE CASTER
BREAK-AWAY KIT

AXLES

102" WIDE RUBBER TORSION
5200# 6-BOLT ELECTRIC BRAKES

WHEELS & TIRES

FIVE 15 X 6 STEEL WHEELS
FIVE 225/75R15 6-PLY RADIAL TIRES
FOUR STAINLESS STEEL SIMULATORS
SPARE TIRE CARRIER

STANDARD FEATURES

WEDGE NOSE
PERMANENT STRAIGHT BULKHEAD WALL
FULL WIDTH REAR RAMP WITH DUTCH DOORS ABOVE WITH WINDOWS
DRESSING ROOM DOOR AT FRONT WITH WINDOW AND CAMPER LATCH WITH DEAD BOLT
WALK THRU DOORS WITH WINDOW, CAMPER LATCH & BUTTERFLY LATCH (ONE EACH SIDE)
ALL DOORS ARE INSULATED AND LINED ON INSIDE OF TRAILER
BUS WINDOWS W/ BARS IN HORSE COMPARTMENT (ONE EACH SIDE)
SIDE WALLS IN HORSE COMPARTMENT ARE DOUBLE WALLED AND INSULATED
ALL WALLS IN HORSE COMPARTMENT ARE RUBBER LINED
REMOVABLE DIVIDER WITH WITHERS SHIELD & SWINGING HEAD SHIELD PINNED TO REMOVABLE POST AT FRONT OF TRAILER

FEED BAGS (ONE PER HORSE)
2-WAY ROOF VENTS (ONE PER HORSE)
INSIDE TIES (TWO PER HORSE)
OUTSIDE TIES (TWO PER HORSE)
TACK ACCESSORIES: TEN BRIDLE HOOKS
PADDING IN HORSE COMPT. ON STALL SIDE WALLS AND EACH SIDE OF DIVIDER
PADDED BUTT BAR AND BREAST BAR IN EACH STALL
CARPET ON FLOOR OF DRESSING ROOM AREA
FLOOR MATS COVERING ENTIRE HORSE COMPARTMENT
TAPER INNER WHEEL WELLS UP & TEAR DROP FENDERS
RUBBER DOCK BUMPERS
FOUR INTERIOR L.E.D. LIGHTS
TWO PAIRS OF FULLY ENCLOSED L.E.D. TAIL LIGHTS
D.O.T. APPROVED L.E.D. RUNNING LIGHTS

CUSTOM GRAPHICS PACKAGE

